

**MAITRE D'OUVRAGE**

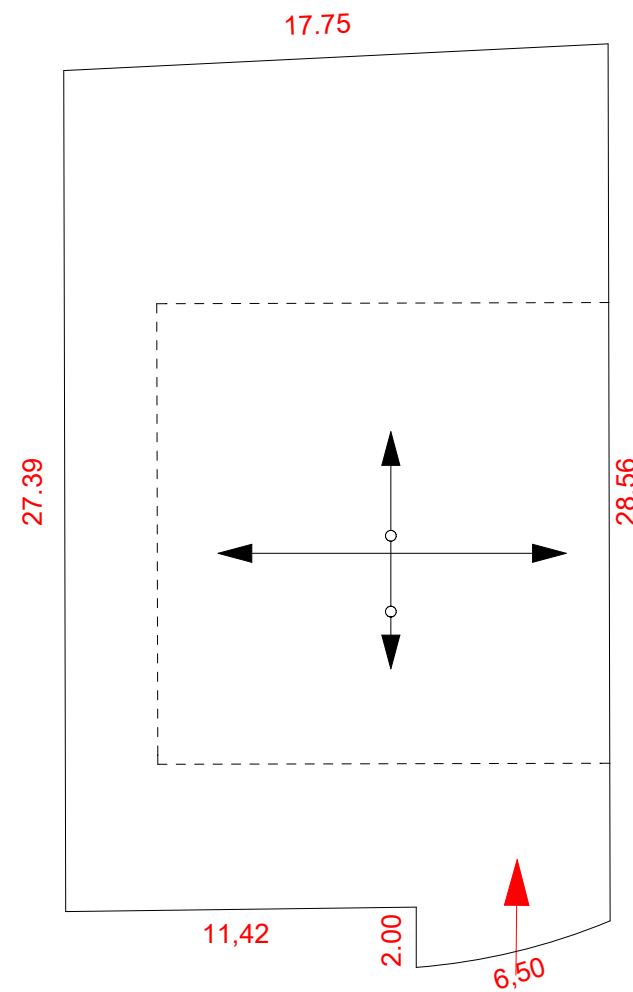

# PROJET ET REALISATION D'UN LOTISSEMENT DE 9 LOTS "LES CIGOGNES" 15 RUE DES CHARRIERES 21120 GEMEAUX

## PLAN DE REPERAGE

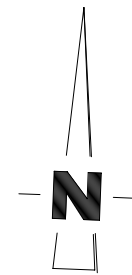
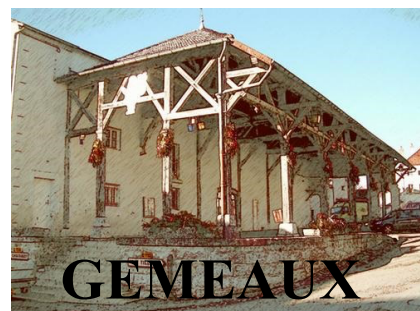
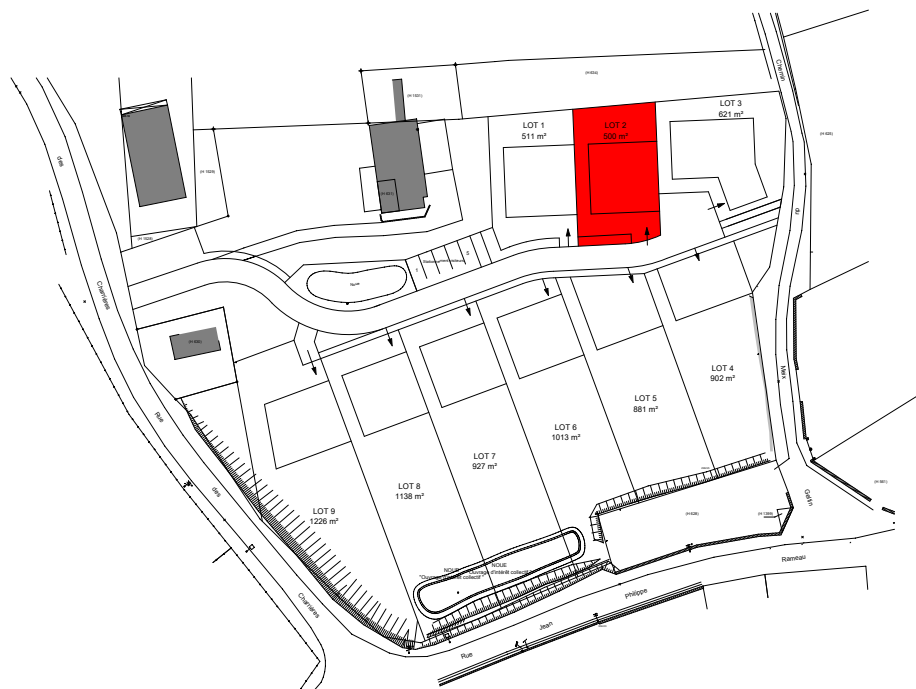

SENS DE FAITAGE PRINCIPAL  
PERPENDICULAIRE A LA PENTE

SENS DE FAITAGE SECONDAIRE  
( HT INFERIEUR AU FAITAGE PRINCIPAL)

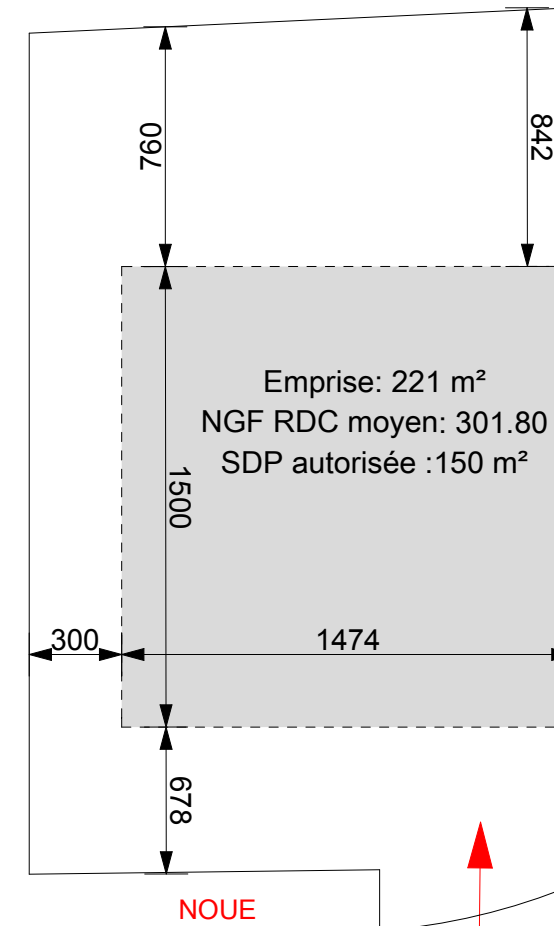

TOUS LES RÉSEAUX AEP / FT/ ERDF / GRDF / EU  
SONT À DISPOSITION EN LIMITE DE PROPRIÉTÉ  
CÔTÉ RUE A L'EXCEPTION DES EP. LES EAUX  
PLUVIALES SERONT RACCORDÉES  
DIRECTEMENT DANS LA NOUE

# LOT 2 500 m<sup>2</sup>



## LEGENDE



Entrée de principe